

NAVE OHANA

52,000 MT Product/Chemical Tanker

30



Contents



By Builder



By Ship Type





Contents



By Builder



By Ship Type

NAVE OHANA 52,000 MT Product/Chemical Tanker 30

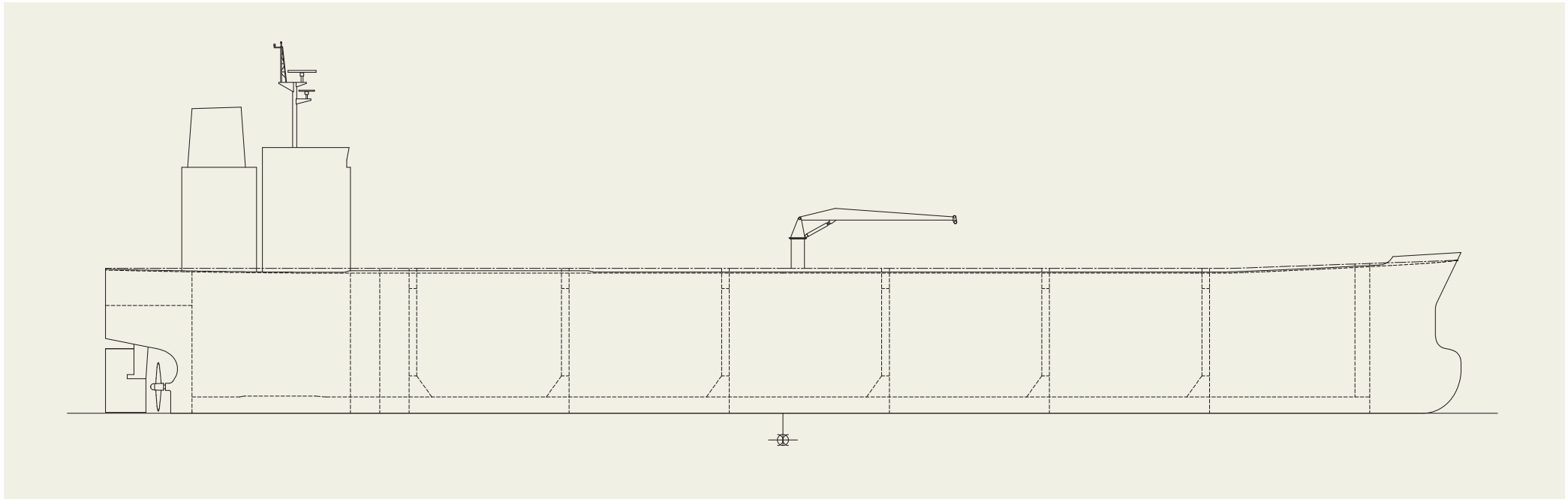

PRINCIPAL PARTICULARS

Length (o.a.).....	184.94 m	Deadweight	49,994 tons
Breadth (mld.).....	32.20 m	Main engine.....	6S50ME-C10.6
Depth (mld.).....	19.10 m	Speed (service).....	abt.14.5 knots
Gross tonnage	30,591	Classification.....	NK
		Builder.....	Minaminippon Shipbuilding Co., Ltd. of the Group



VERDE HERALDO 209,000 MT Bulk Carrier 36



Contents



By Builder



By Ship Type





Contents



By Builder

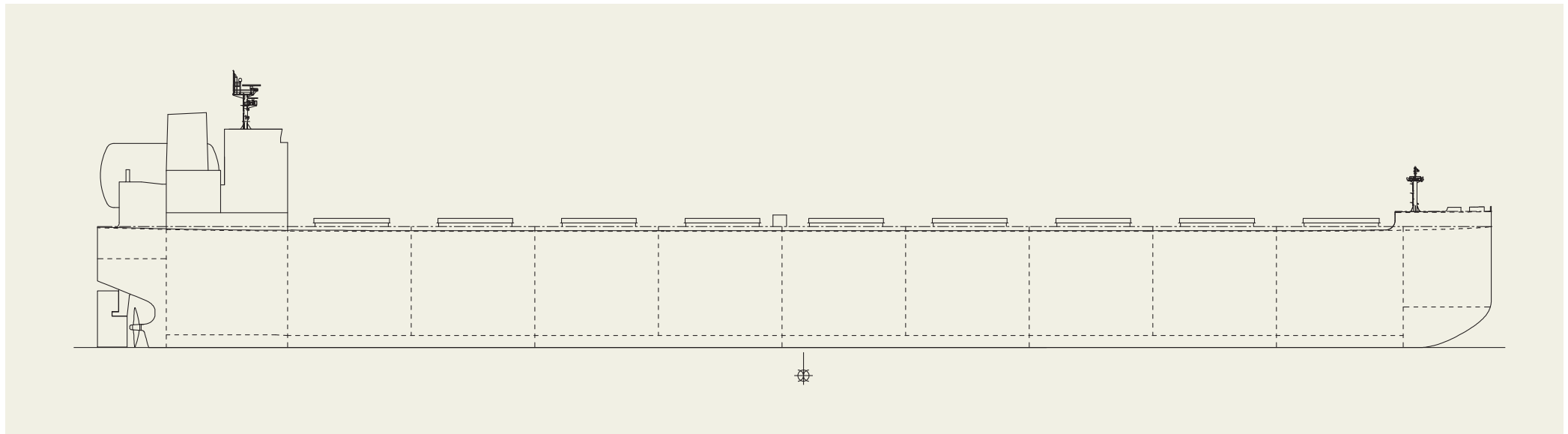

By Ship Type

VERDE HERALDO 209,000 MT Bulk Carrier 36**PRINCIPAL PARTICULARS**

Length (o.a.).....	299.99 m	Deadweight	210,321 tons
Breadth (mld.).....	50.00 m	Main engine.....	7S60ME-C10.5-GI
Depth (mld.).....	25.00 m	Speed (service)	abt.14.0 knots
Gross tonnage	110,708	Classification.....	NK
		Builder.....	Imabari Shipbuilding Co., Ltd. / Saijo Shipyard



CAPE SUZURAN 181,000 MT Bulk Carrier 37



Contents



By Builder



By Ship Type





Contents



By Builder

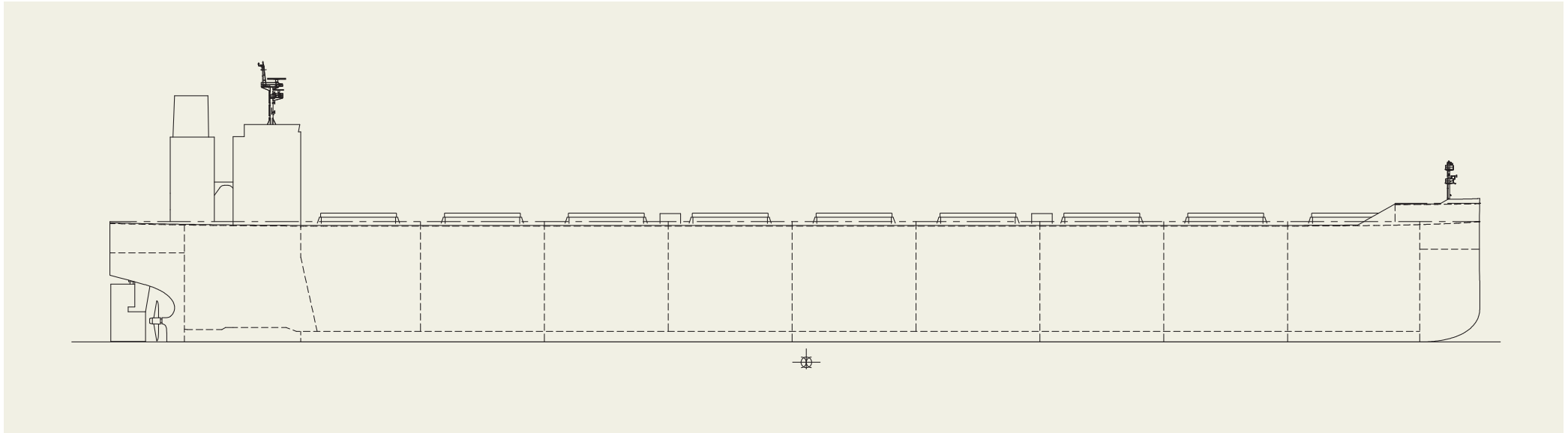

By Ship Type

CAPE SUZURAN 181,000 MT Bulk Carrier 37**PRINCIPAL PARTICULARS**

Length (o.a.).....	291.96 m	Deadweight	182,098 tons
Breadth (mld.)	45.00 m	Main engine.....	7S60ME-C10.6
Depth (mld.).....	24.70 m	Speed (service)	abt.13.65 knots
Gross tonnage	94,321	Classification.....	NK
		Builder.....	Imabari Shipbuilding Co., Ltd. / Saijo Shipyard



MANHASSET QUEEN 64,000 MT Bulk Carrier 52



Contents



By Builder



By Ship Type





Contents



By Builder



By Ship Type

MANHASSET QUEEN 64,000 MT Bulk Carrier 52

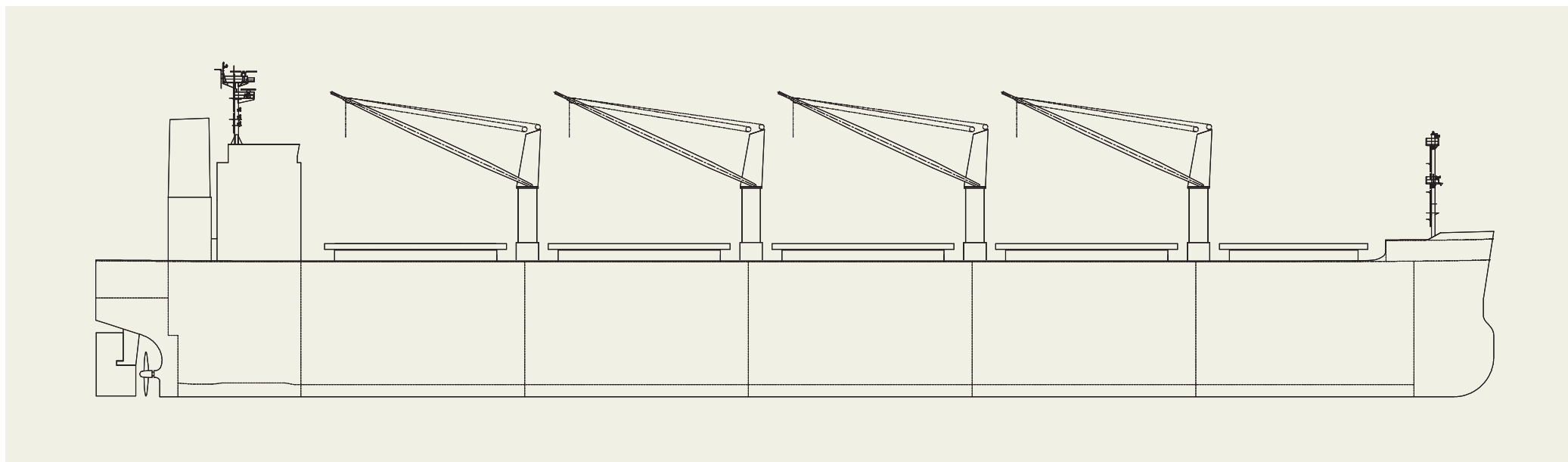

PRINCIPAL PARTICULARS

Length (o.a.) 199.98 m
 Breadth (mld.) 32.24 m
 Depth (mld.) 19.30 m
 Gross tonnage 36,139
 Deadweight 63,654 tons

Main engine 6S50ME-C9.7
 Speed (service) abt.14.0 knots
 Classification NK
 Builder Imabari Shipbuilding Co., Ltd. /
 Head Office & Imabari Shipyard



MERSEA ISLAND 40,000 MT Bulk Carrier 61



Contents



By Builder



By Ship Type





Contents



By Builder

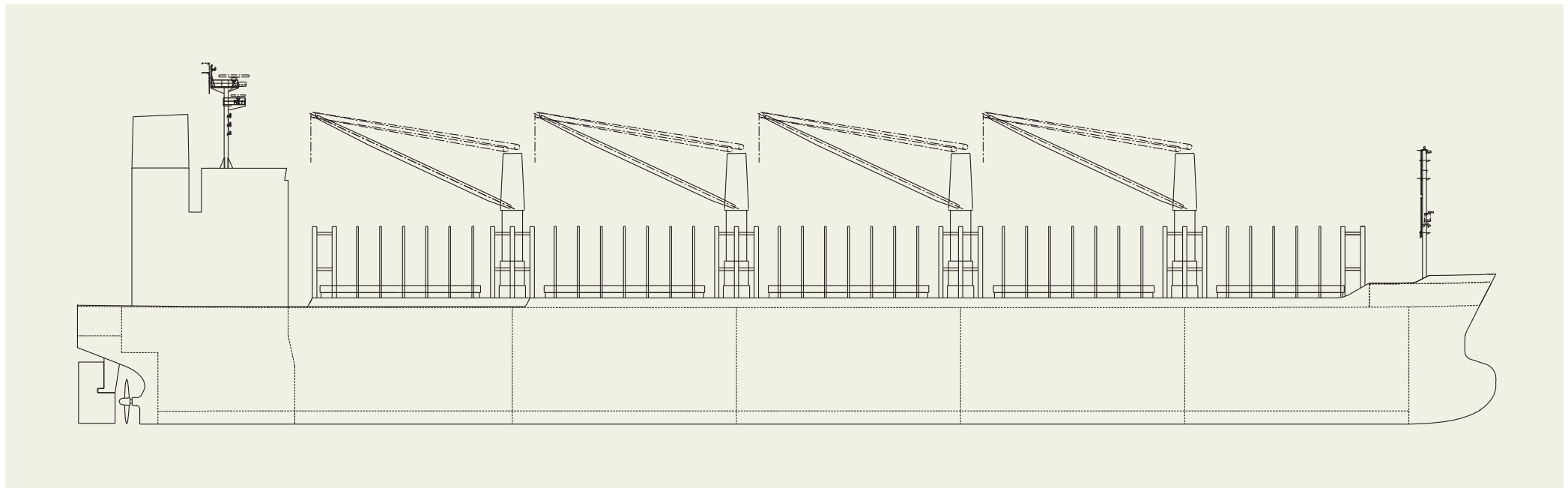

By Ship Type

MERSEA ISLAND 40,000 MT Bulk Carrier **61****PRINCIPAL PARTICULARS**

Length (o.a.).....	182.93 m	Deadweight	40,058 tons
Breadth (mld.).....	31.00 m	Main engine.....	6G45ME-C9.7
Depth (mld.).....	15.00 m	Speed (service)	abt.13.7 knots
Gross tonnage	25,240	Classification.....	NK
		Builder.....	Shimanami Shipyard Co., Ltd. of the Group



CMA CGM KRUGER 5,800 TEU Containership 71



Contents



By Builder



By Ship Type





Contents



By Builder



By Ship Type

CMA CGM KRUGER 5,800 TEU Containership 71

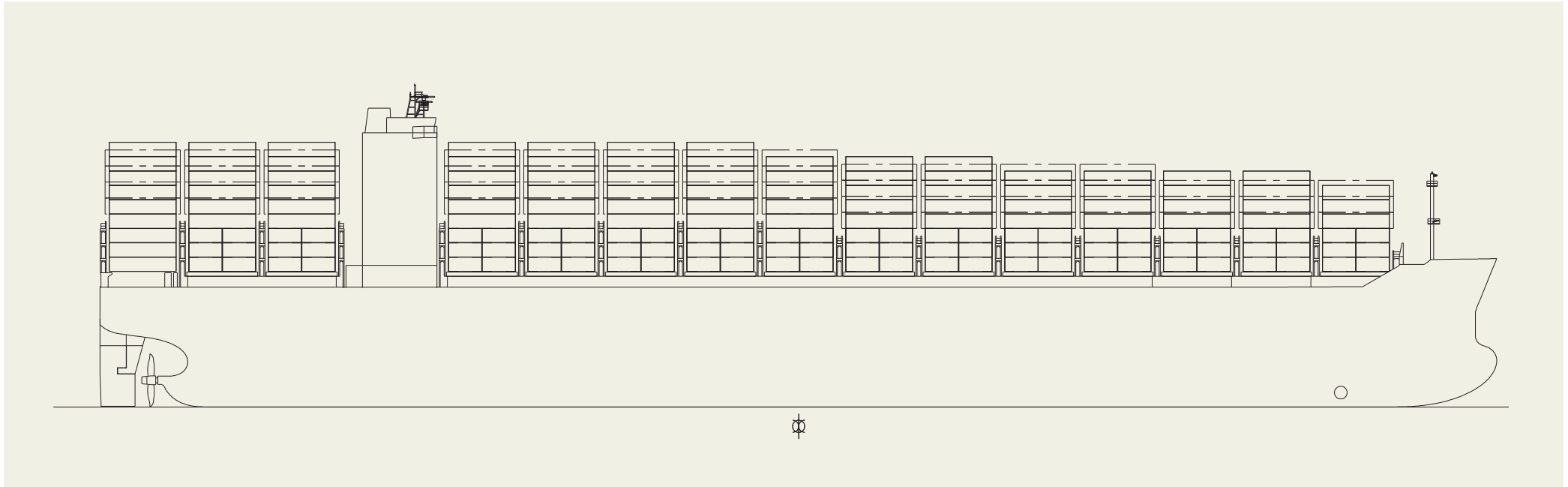

PRINCIPAL PARTICULARS

Length (o.a.).....	254.94 m	Main engine.....	6G80ME-C10.6
Breadth (mld.).....	40.00 m	Speed (service).....	abt. 21.5 knots
Depth (mld.).....	21.70 m	Classification.....	ABS
Gross tonnage.....	57,907	Loading capacity (container).....	5,800 TEU
		Builder.....	Imabari Shipbuilding Co., Ltd. / Hiroshima Shipyard



ONE INTELLIGENCE 24,000 TEU Containership 72



Contents



By Builder



By Ship Type





Contents



By Builder



By Ship Type

ONE INTELLIGENCE 24,000 TEU Containership 72

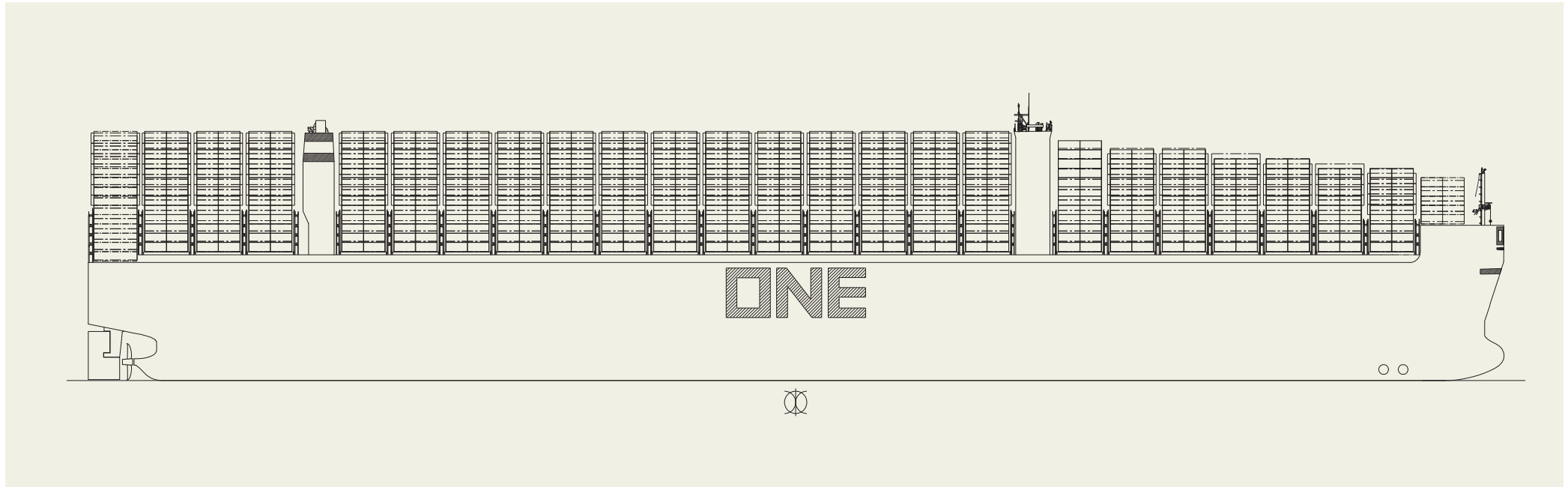

PRINCIPAL PARTICULARS

Length (o.a.).....	399.95 m	Main engine.....	9G95ME-C10.6
Breadth (mld.).....	61.40 m	Speed (service).....	abt.21.00 knots
Depth (mld.).....	33.20 m	Classification.....	DNV
Gross tonnage.....	235,311	Loading capacity (container).....	24,000 TEU
		Builder.....	Imabari Shipbuilding Co., Ltd. / Saijo Shipyard



MAERSK NOTODDEN 2,080 TEU Containership 73



Contents



By Builder



By Ship Type





Contents



By Builder



By Ship Type

MAERSK NOTODDEN 2,080 TEU Containership 73

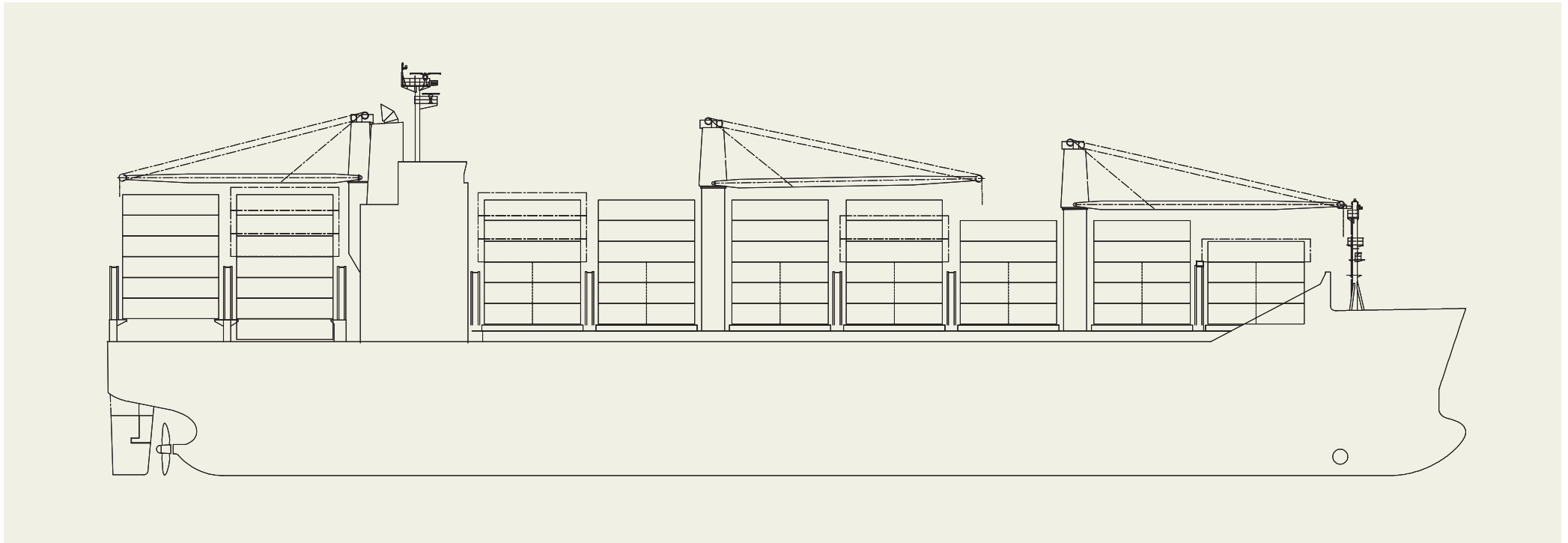

PRINCIPAL PARTICULARS

Length (o.a.).....	171.93 m	Speed (service)	abt. 18.0 knots
Breadth (mld.)	32.20 m	Classification.....	ABS
Depth (mld.).....	16.80 m	Loading capacity (container).....	2,080 TEU
Gross tonnage	25,723	Builder.....	Imabari Shipbuilding Co., Ltd. / Head Office & Imabari Shipyard
Main engine.....	6S60ME-C10.6		



ONE SINGAPORE 13,900 TEU Containership 74



Contents



By Builder



By Ship Type





Contents



By Builder



By Ship Type

ONE SINGAPORE 13,900 TEU Containership 74

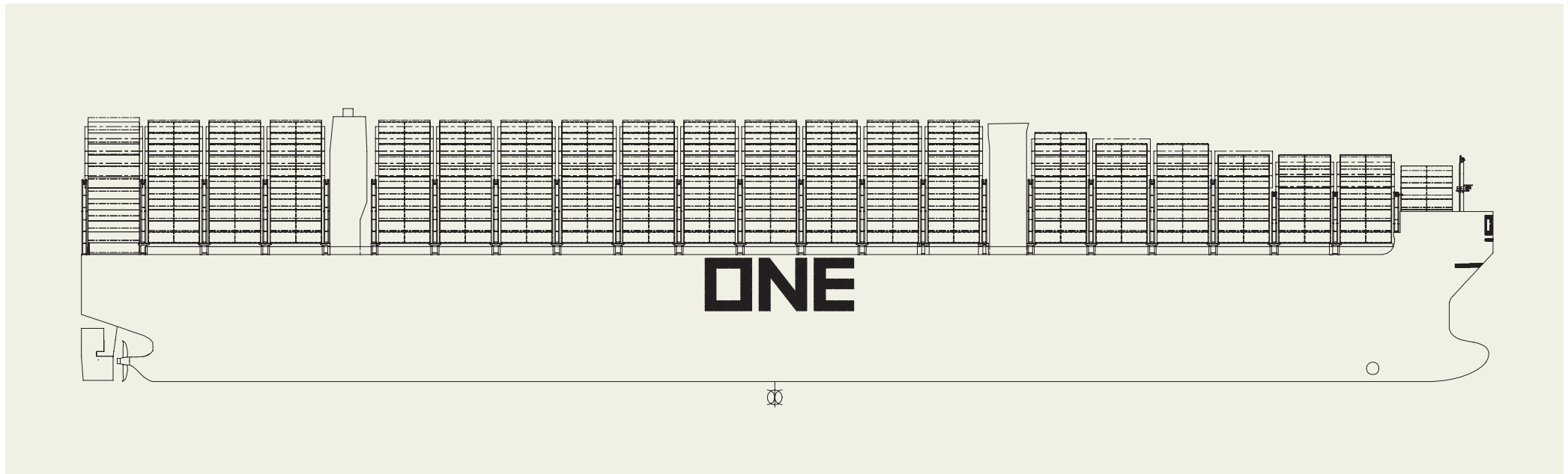

PRINCIPAL PARTICULARS

Length (o.a.).....	335.94 m	Main engine.....	7G95ME-C10.6
Breadth (mld.).....	51.00 m	Speed (service).....	abt. 22.0 knots
Depth (mld.).....	30.10 m	Classification.....	LR
Gross tonnage.....	140,233	Loading capacity (container).....	13,900 TEU
		Builder.....	Imabari Shipbuilding Co., Ltd. / Hiroshima Shipyard

USSAMA BHUM 11,000 TEU Containership 75



Contents



By Builder



By Ship Type





Contents



By Builder



By Ship Type

USSAMA BHUM 11,000 TEU Containership 75

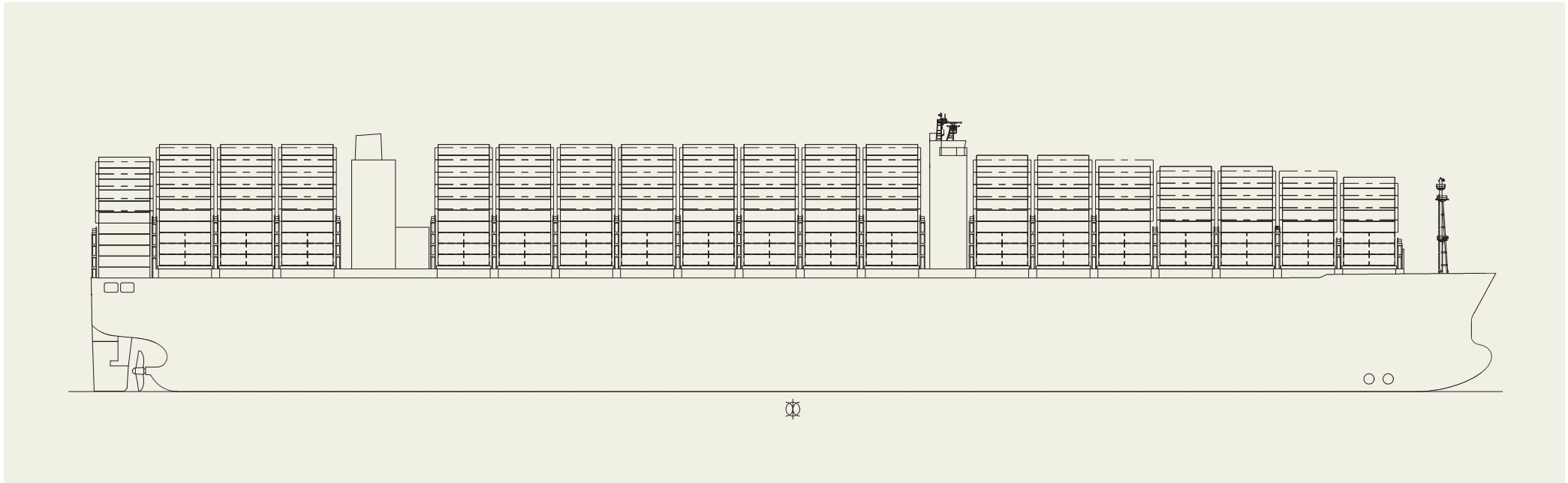

PRINCIPAL PARTICULARS

Length (o.a.)333.95 m
 Breadth (mld.) 48.40 m
 Depth (mld.)26.8 m
 Gross tonnage118,523

Main engine9S90ME-C10.5
 Speed (service)abt. 23.0 knots
 Classification NK
 Loading capacity (container) 11,000 TEU
 Builder Imabari Shipbuilding Co., Ltd. / Hiroshima Shipyard



SWEET PEA LEADER 7,000 CARS TYPE LNG Dual-fuelled Vehicles Carrier 82



Contents



By Builder



By Ship Type





Contents



By Builder



By Ship Type

SWEET PEA LEADER 7,000 CARS TYPE LNG Dual-fuelled Vehicles Carrier 82

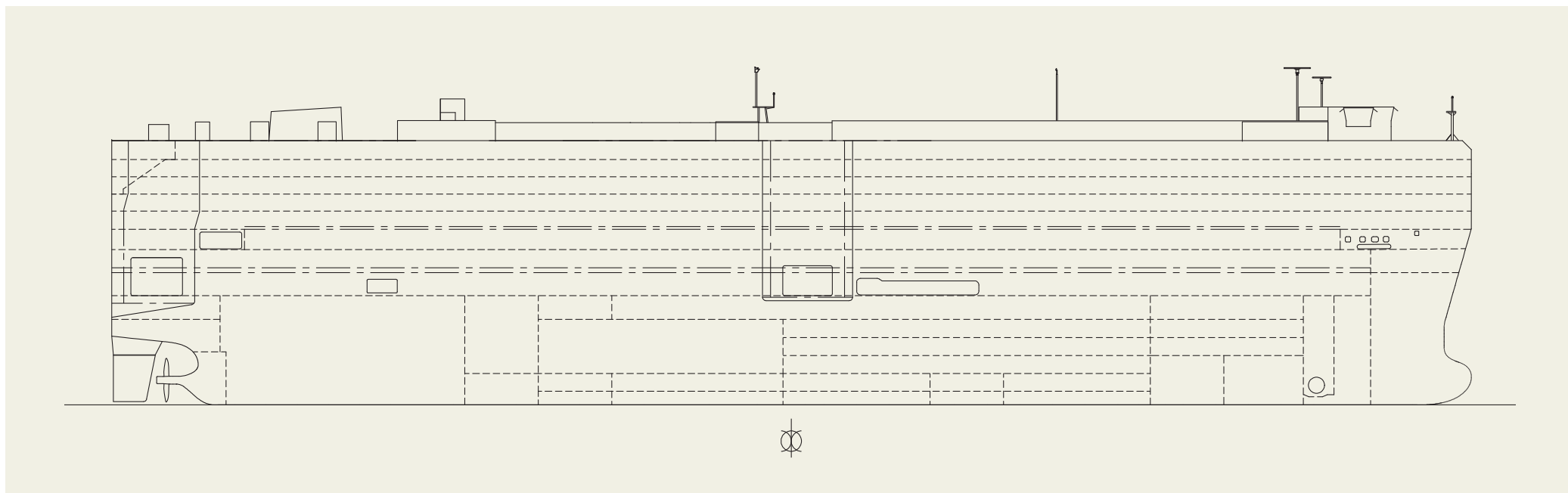

PRINCIPAL PARTICULARS

Length (o.a.).....	199.93 m	Main engine.....	6S60ME-C10.5-GI-EGRBP
Breadth (mld.).....	38.0 m	Speed (service).....	abt.18.0 knots
Depth (mld.).....	38.76 m	Classification.....	NK
Gross tonnage.....	77,644	Loading capacit (car/vehicle).....	7,000 Cars Type
Deadweight.....	18,534 tons	Builder.....	Tadotsu Shipyard Co., Ltd. of the Group

